

THIS DRAWING IS UNPUBLISHED. RELEASED FOR PUBLICATION OCT. 2001.
 © COPYRIGHT 2001 By - ALL RIGHTS RESERVED.

LOC	DIST	REVISIONS			
P	LTR	DESCRIPTION	DATE	DWN	APVD
J	/				
	K3	REVISED PER ECO-11-005033	28MAR11	RK	HMR

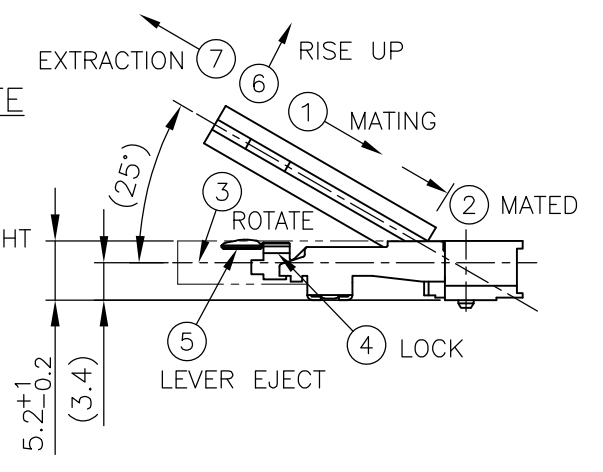

- (APPLIED TO SHEET 1-2)
- MATERIAL ; HOUSING: HIGH TEMPERATURE THERMO PLASTIC UL94V-0
CONTACT: COPPER ARROY
LOCK LEVER STAINLESS STEEL
SOLDER PEG: COPPER ARROY
 - FINISH ; CONTACT AREA: GOLD FLASH ON 0.0013MIN ALL OVER NICKEL.
SOLDERING AREA: GOLD FLASH PLT.
SOLDER PEG: TIN PLATING.
- ⚠ MECHANICAL KEY POSITION OF CONNECTOR SEE TABLE.
 - ⚠ TOLERANCES NON-CUMULATIVE.
 - ⚠ NOT TO SCALE.
 - ⚠ [] INSIDE MUST BE RESIST COAT EXCEPT SOLDER PATTERN.
7. IF THE MODULE DOESN'T INSERT AND LOCK IN THE LATCH SMOOTHLY, OPEN WIDE BOTH LATCHES BY MANUAL. AND THE MODULE MUST BE INSERTED AND LOCKED IN THE LATCH.

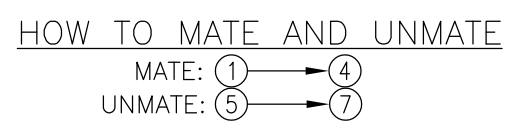
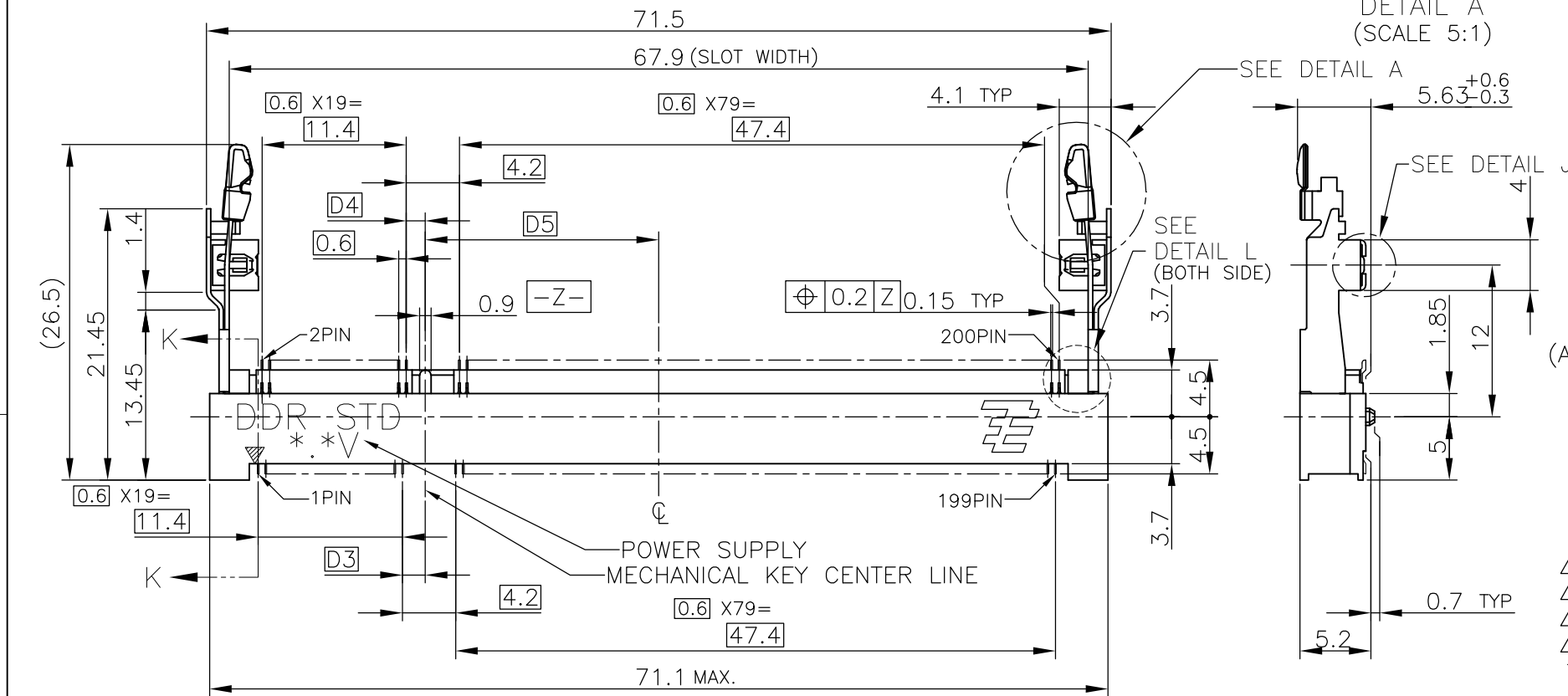
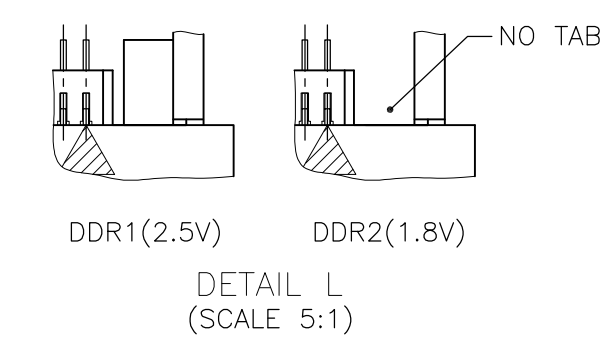
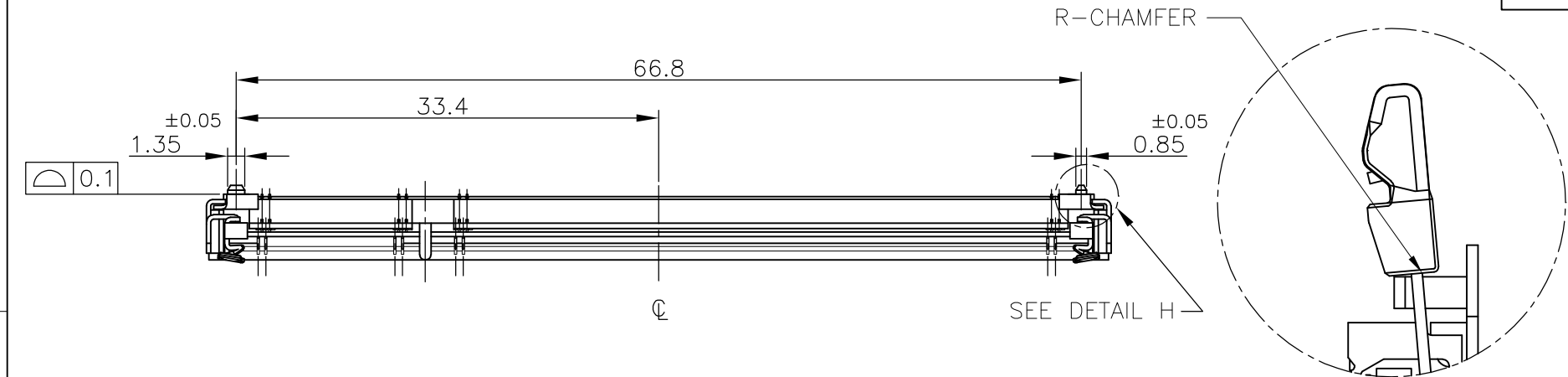
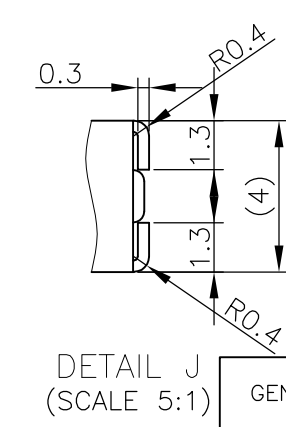
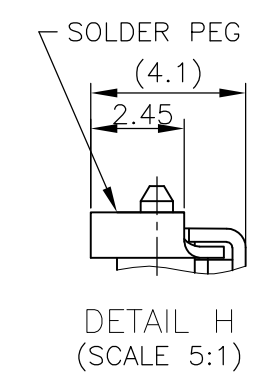
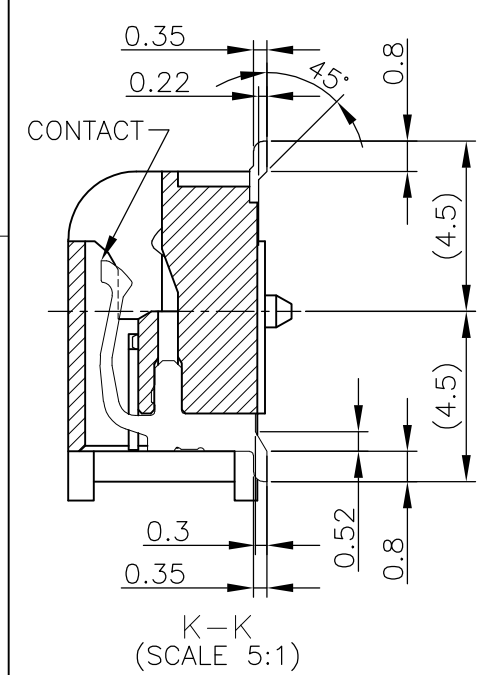

GENERAL TOLERANCE
 10 ≥ : ±0.2
 30 ≥ > 10 : ±0.25
 100 ≥ > 30 : ±0.3
 ANGLES : ±3°

TIN PLATING	AVAILABLE	1.8V (DDR2)	17.55	2.4	2.7	200	1-1473149-4
	AVAILABLE	1.8V (DDR2)	17.55	2.4	2.7	200	1473149-4
	AVAILABLE	2.5V (DDR1)	18.45	1.5	1.8	200	1473149-1
REMARK (PEG)	TOOLING STATUS	POWER SUPPLY	D5	D4	D3	POS	PART NO.
THIS DRAWING IS A CONTROLLED DOCUMENT.		DWN T.FUMIKURA	16JAN02		TE Connectivity DDR1 & DDR2 SODIMM SOCKET 0.6mm PITCH 200POS STANDARD PROFILE STANDARD TYPE (NEW LATCH TYPE)		
DIMENSIONS: MM		CHK T.KUSUHARA	17JAN02				
TOLERANCES UNLESS OTHERWISE SPECIFIED:		APVD I.ENOMOTO	17JAN02				
0 PLC ± 1 PLC ± 2 PLC ± 3 PLC ± 4 PLC ± ANGLES ±		PRODUCT SPEC	NAME				
MATERIAL		FINISH		108-5701		DRAWING NO	
		WEIGHT		4.7g		RESTRICTED TO	
CUSTOMER DRAWING			SCALE		SHEET		REV
			2:1		1 OF 4		K3

THIS DRAWING IS UNPUBLISHED. RELEASED FOR PUBLICATION OCT ,2001.

© COPYRIGHT 2001 By - ALL RIGHTS RESERVED.

LOC		DIST		REVISIONS					
J				P	LTR	DESCRIPTION	DATE	DWN	APVD
				-	-	SEE SHEET 1	-	-	-

REFERENCE P.C.BOARD PATTERN LAYOUT (CONNECTOR MOUNTING SIDE)

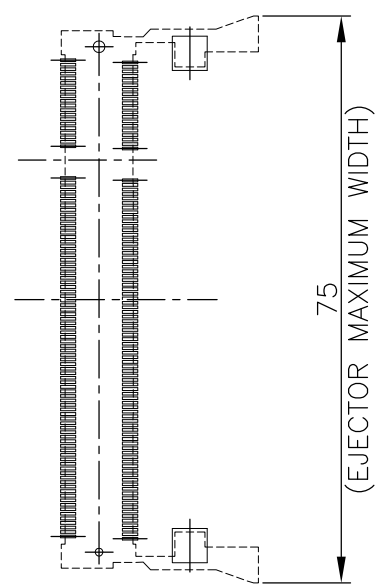

REAL SIZE (SCALE 1:1)

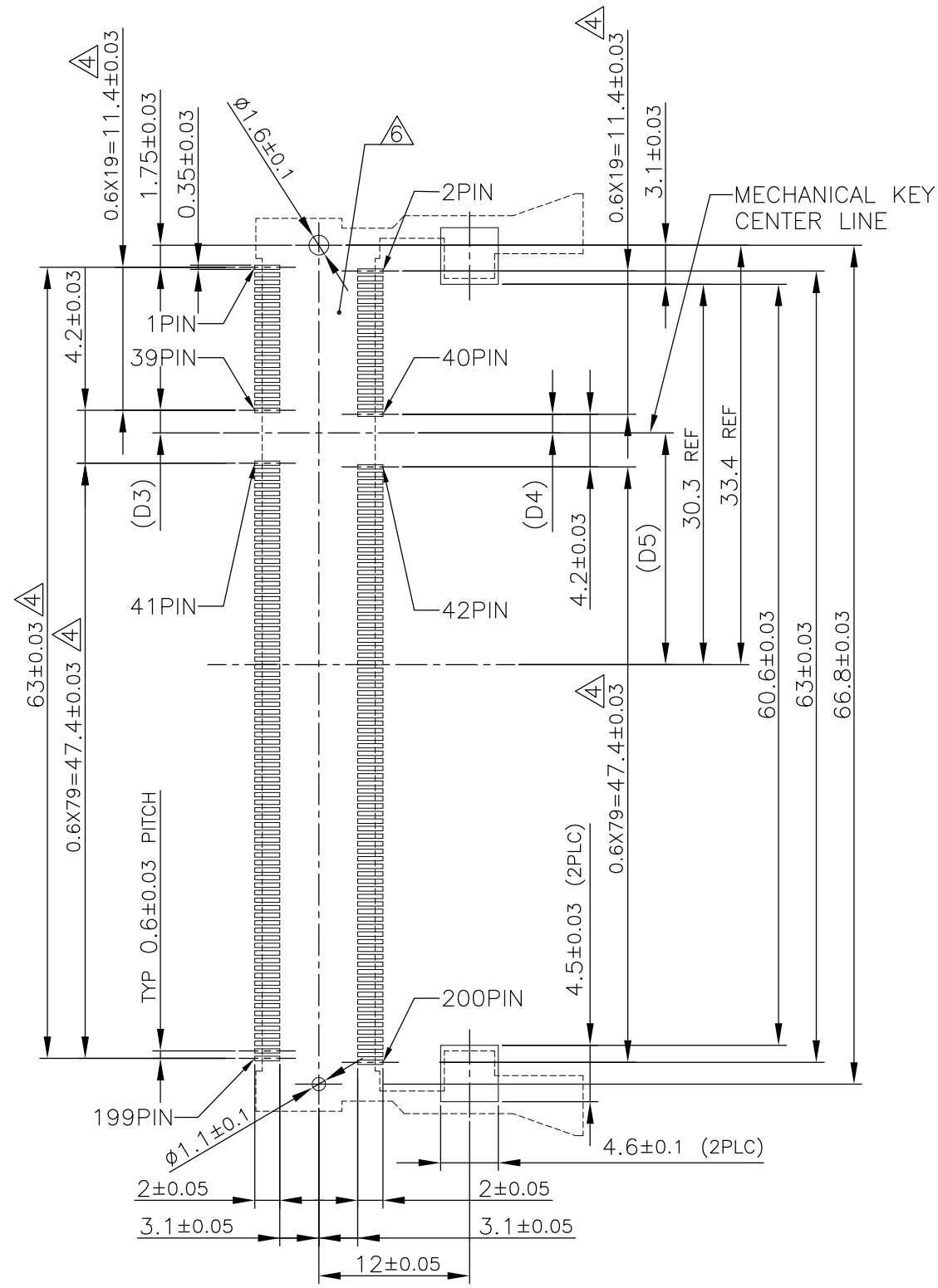

1.8V	17.55	2.4	2.7
2.5V	18.45	1.5	1.8
POWER SUPPLY	D5	D4	D3

THIS DRAWING IS A CONTROLLED DOCUMENT.		DWN	STE TE Connectivity		
DIMENSIONS: MM		CHK			
TOLERANCES UNLESS OTHERWISE SPECIFIED:		APVD	NAME		
0 PLC ±		PRODUCT SPEC	DDR1 & DDR2 SODIMM SOCKET		
1 PLC ±		APPLICATION SPEC	0.6mm PITCH 200POS		
2 PLC ±			STANDARD PROFILE STANDARD TYPE (NEW LATCH TYPE)		
3 PLC ±			SIZE	CAGE CODE	DRAWING NO
4 PLC ±			A3	00779	C-1473149
ANGLES ±		WEIGHT	RESTRICTED TO		
FINISH		CUSTOMER DRAWING	SCALE	SHEET	REV
			2:1	2 OF 4	K3

THIS DRAWING IS UNPUBLISHED. RELEASED FOR PUBLICATION OCT. 2001.
 © COPYRIGHT 2001 By - ALL RIGHTS RESERVED.

LOC	DIST	REVISIONS			
P	LTR	DESCRIPTION	DATE	DWN	APVD
J	/	SEE SHEET 1	-	-	-

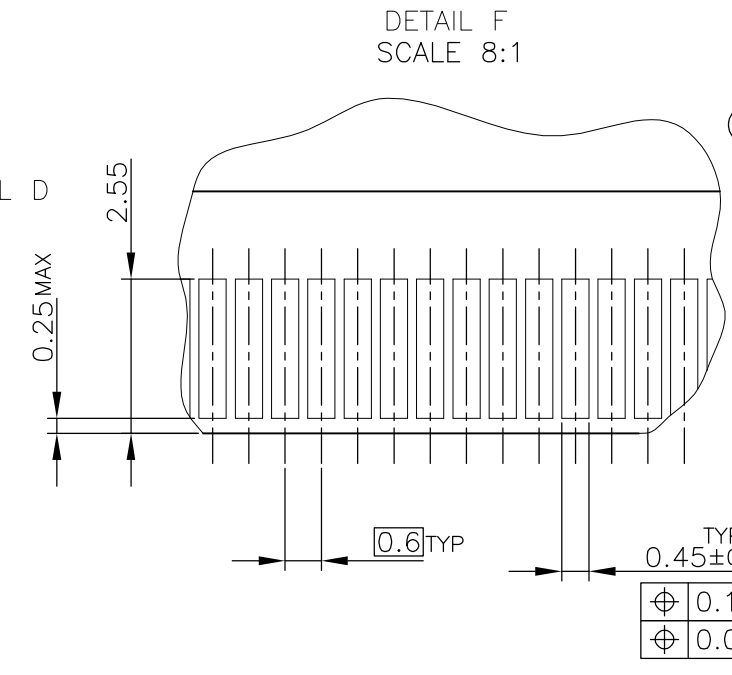
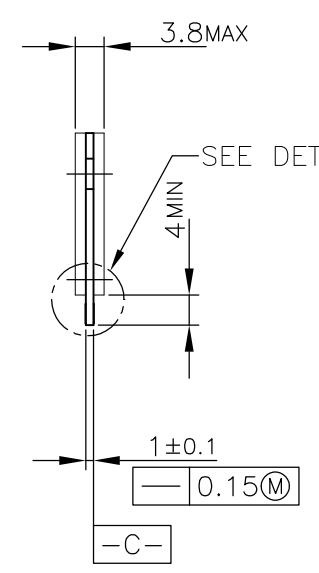
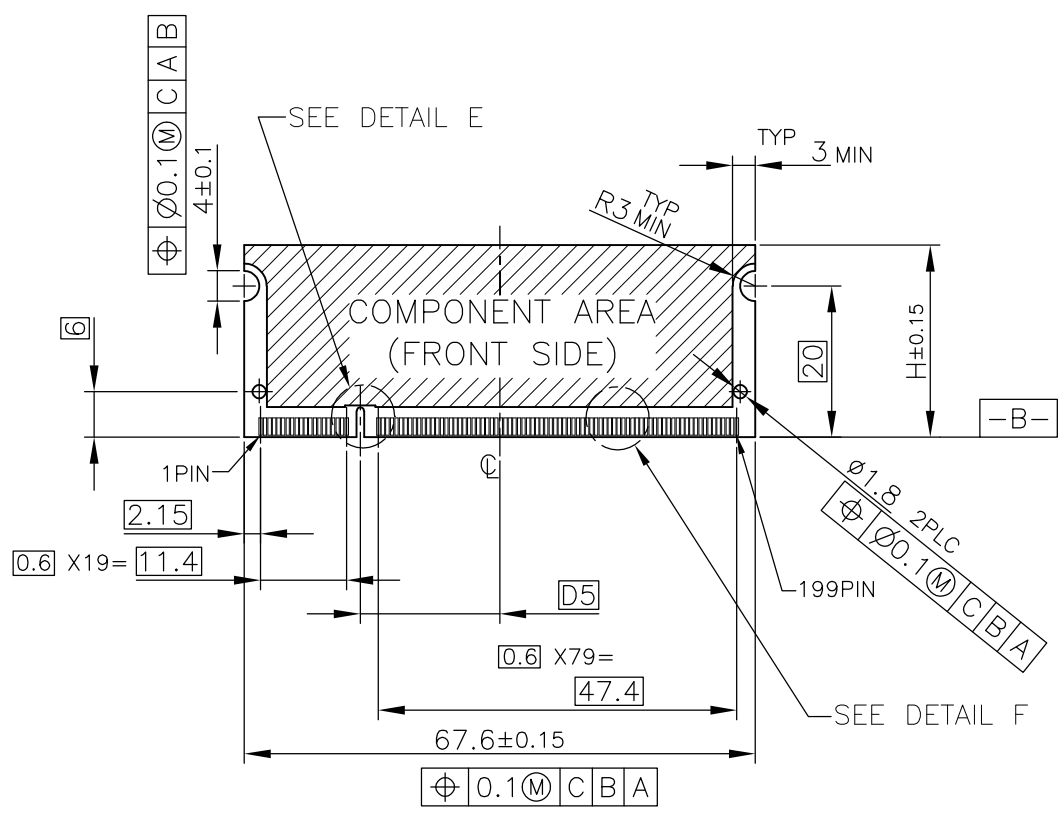

- (APPLIED TO SHEET 3)
1. TOLERANCES ON ALL DIMENSIONS ±0.15 UNLESS OTHERWISE SPECIFIED.
 2. P.C. BOARD THICKNESS APPLIES ACROSS TABS AND INCLUDES PLATING AND/OR METALIZATION.
 3. FINISH OF PAD : GOLD PLATING 0.00076 MIN. OVER Ni PLATING 0.002MIN.
- △ NO BURR
 △ CHAMFER 0.25 MAX x 45° IF EXIST.

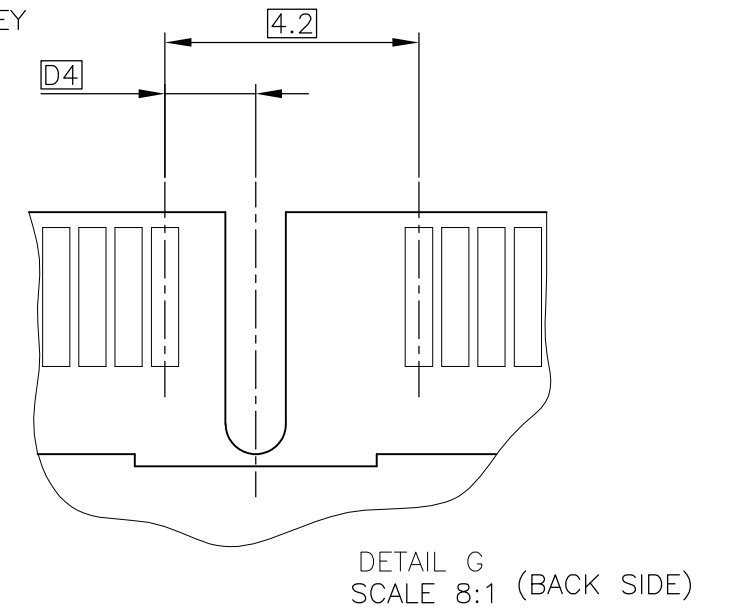
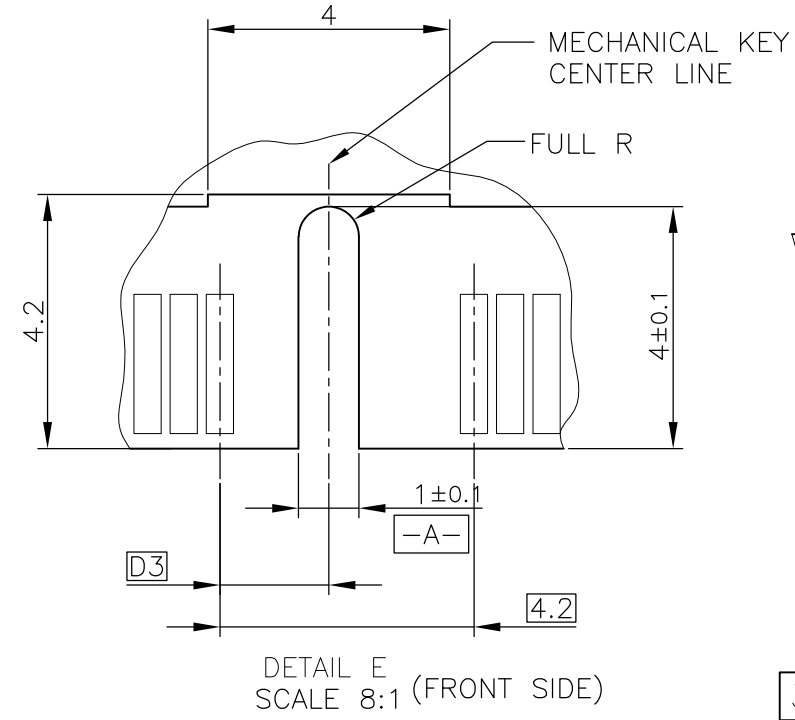
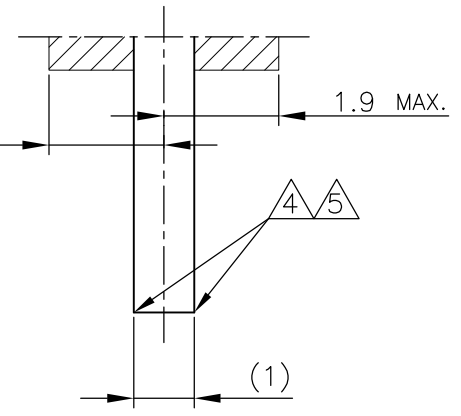
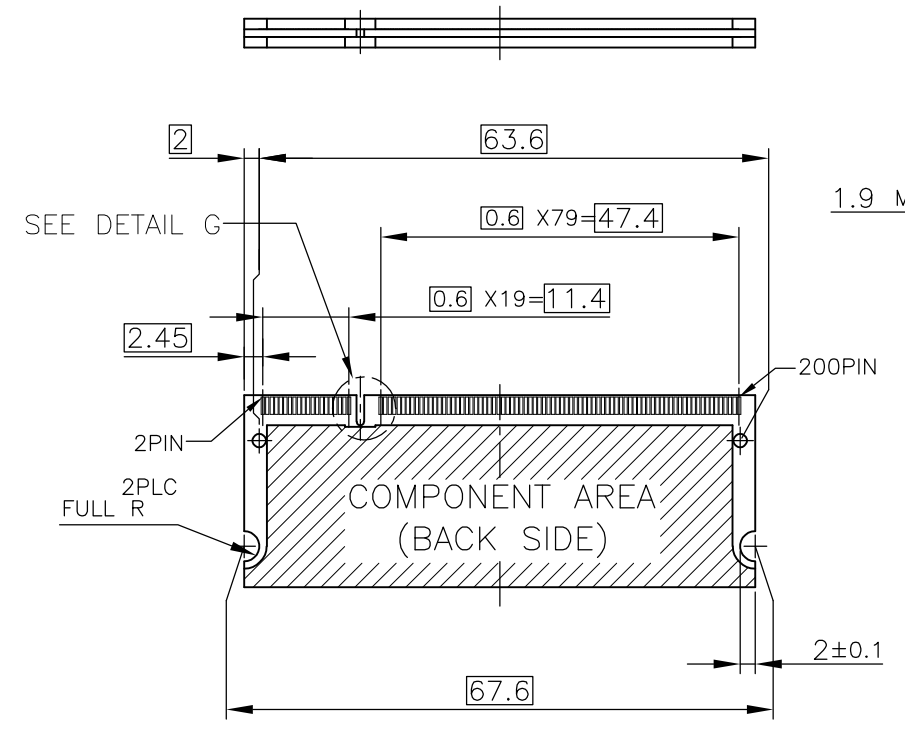

RECOMMENDED MATING P.C.B CONFIGURATION

THIS DRAWING IS A CONTROLLED DOCUMENT.		DWN
DIMENSIONS: MM		CHK
TOLERANCES UNLESS OTHERWISE SPECIFIED:		APVD
0 PLC	±	PRODUCT SPEC
1 PLC	±	APPLICATION SPEC
2 PLC	±	WEIGHT
3 PLC	±	
4 PLC	±	
ANGLES	±	
FINISH		
MATERIAL		

31.75	1.8V	17.55	2.4	2.7
25.4	2.5V	18.45	1.5	1.8
H	POWER SUPPLY	D5	D4	D3

STE TE Connectivity

NAME: DDR1 & DDR2 SODIMM SOCKET
 0.6mm PITCH 200POS
 STANDARD PROFILE STANDARD TYPE (NEW LATCH TYPE)

SIZE	CAGE CODE	DRAWING NO	RESTRICTED TO
A3	00779	C-1473149	-

CUSTOMER DRAWING SCALE 2:1 SHEET 3 OF 4 REV K3

THIS DRAWING IS UNPUBLISHED. RELEASED FOR PUBLICATION OCT , 2001.
 © COPYRIGHT 2001 By - ALL RIGHTS RESERVED.

LOC	DIST	REVISIONS			
P	LTR	DESCRIPTION	DATE	DWN	APVD
J	/	SEE SHEET 1	-	-	-

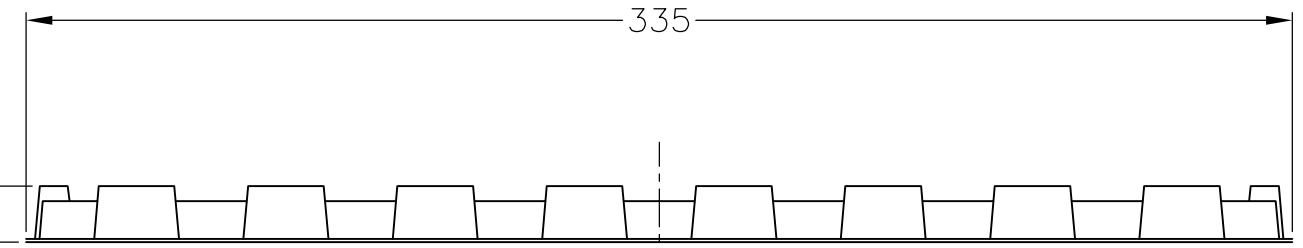
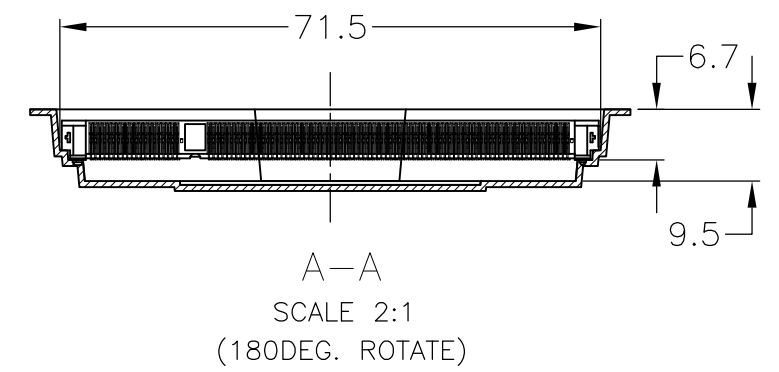
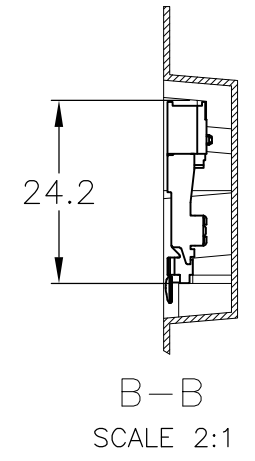
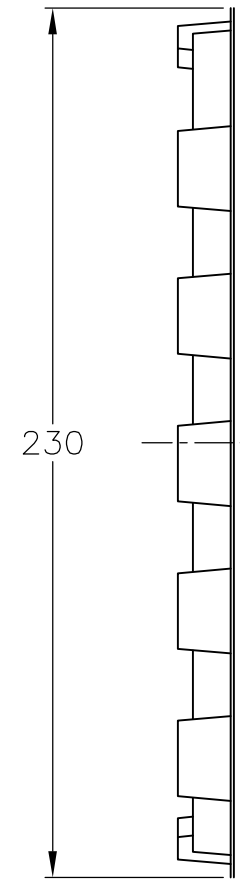
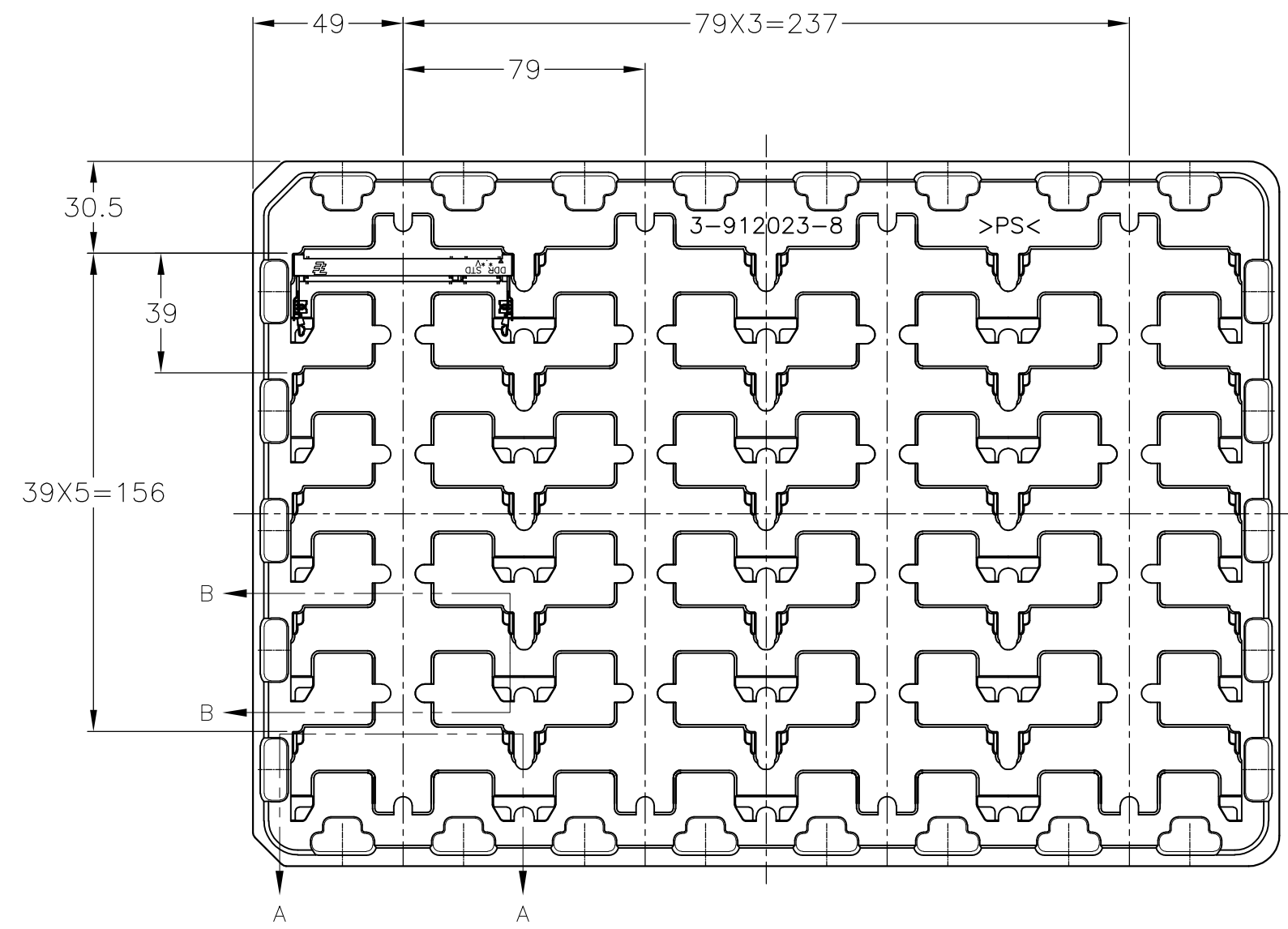

DDR2	20EA/TRAY	1-1473149-4
DDR2	20EA/TRAY	1473149-4
DDR1	20EA/TRAY	1473149-1
REMARK	QTY	P/N

14.8

- (APPLIED TO SHEET 4)
- 1 THE DIRECTION OF EACH CONNECTOR ON A TRAY IS REFERRED TO THIS DRAWING.
 - 2 GENERAL TOLERANCE: ±0.5

THIS DRAWING IS A CONTROLLED DOCUMENT.		DWN	TE Connectivity NAME DDR1 & DDR2 SODIMM SOCKET 0.6mm PITCH 200POS STANDARD PROFILE STANDARD TYPE (NEW LATCH TYPE)		
DIMENSIONS: MM		CHK			
TOLERANCES UNLESS OTHERWISE SPECIFIED:		APVD			
0 PLC ± 1 PLC ± 2 PLC ± 3 PLC ± 4 PLC ± ANGLES ± FINISH ±		PRODUCT SPEC			
MATERIAL		APVD	APPLICATION SPEC	SIZE	CAGE CODE
		APVD	APPLICATION SPEC	DRAWING NO	
		APVD	APPLICATION SPEC	RESTRICTED TO	
		APVD	APPLICATION SPEC	A300779 C-1473149	
		APVD	APPLICATION SPEC	CUSTOMER DRAWING	
		APVD	APPLICATION SPEC	SCALE 1:2	SHEET 4 OF 4
		APVD	APPLICATION SPEC	REV K3	