

THIS DRAWING IS UNPUBLISHED. RELEASED FOR PUBLICATION  
 © COPYRIGHT BY TYCO ELECTRONICS CORPORATION. ALL RIGHTS RESERVED.

| LOC | DIST | REVISIONS                 |         |     |      |
|-----|------|---------------------------|---------|-----|------|
| P   | LTR  | DESCRIPTION               | DATE    | DWN | APVD |
|     | T    | REVISED PER ECO-10-008441 | 24APR10 | HMR | KW   |

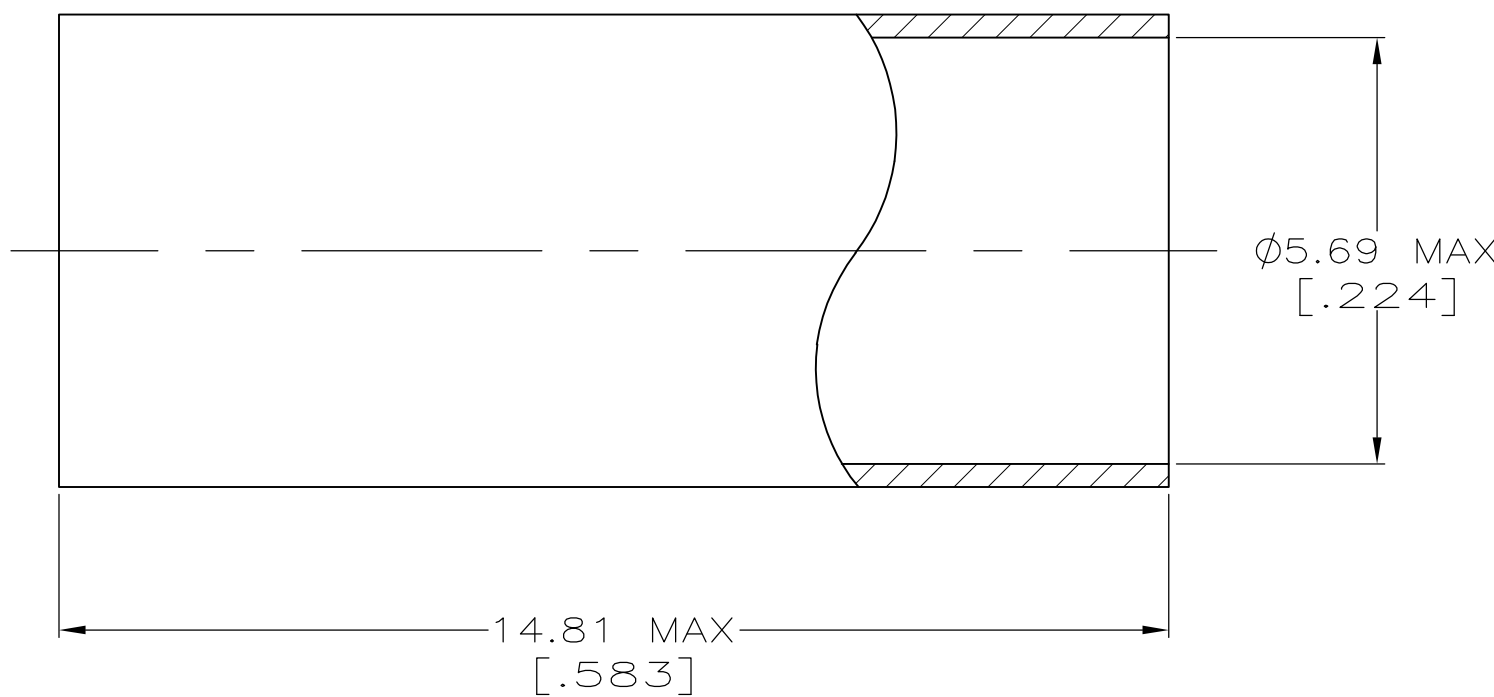

- 1. COPPER ALLOY
- 2. SILVER PLATE PER QQ-S-365, 5.08μm (.000200) MIN THICKNESS.
- 3. TIN-LEAD PLATE PER ASTM-B-545, 2.54μm (.000100) MIN THICKNESS, WITH SUPPLEMENTAL ANTI FRETTING LUBRICANT.
- 4. GOLD PLATE PER MIL-G-45204, 0.76μm (.000030) MIN THICKNESS.
- 5. MATTE TIN PLATE PER MIL-T-10727, 2.54μm (.000100) MIN THICKNESS, WITH SUPPLEMENTAL ANTI FRETTING LUBRICANT.

|        |             |
|--------|-------------|
| 5      | 9-225382-0  |
| 4      | 225382-5    |
| 3      | 225382-3    |
| 2      | 225382-2    |
| FINISH | PART NUMBER |

|  |                     |                                  |   |                    |     |       |     |       |     |       |     |        |     |                       |            |                    |
|--|---------------------|----------------------------------|---|--------------------|-----|-------|-----|-------|-----|-------|-----|--------|-----|-----------------------|------------|--------------------|
| THIS DRAWING IS A CONTROLLED DOCUMENT.   |                     | DWN 14NOV95<br>MICHAEL E. COWHER | Tyco Electronics Corporation<br>Harrisburg, PA 17105-3608 |                    |     |       |     |       |     |       |     |        |     |                       |            |                    |
| DIMENSIONS: MM [INCHES]  |                     | CHK 14NOV95<br>FRANK MORANA      | NAME<br>FERRULE   |                    |     |       |     |       |     |       |     |        |     |                       |            |                    |
| TOLERANCES UNLESS OTHERWISE SPECIFIED:   |                     | APVD 14NOV95<br>FRANK MORANA     | PRODUCT SPEC<br>-   |                    |     |       |     |       |     |       |     |        |     |                       |            |                    |
| <table border="0"> <tr><td>0 PLC</td><td>± -</td></tr> <tr><td>1 PLC</td><td>± -</td></tr> <tr><td>2 PLC</td><td>± -</td></tr> <tr><td>3 PLC</td><td>± -</td></tr> <tr><td>4 PLC</td><td>± -</td></tr> <tr><td>ANGLES</td><td>± -</td></tr> </table> |                     | 0 PLC                            | ± -   | 1 PLC              | ± - | 2 PLC | ± - | 3 PLC | ± - | 4 PLC | ± - | ANGLES | ± - | APPLICATION SPEC<br>- | SIZE<br>A3 | CAGE CODE<br>00779 |
| 0 PLC  | ± -                 |                                  |   |                    |     |       |     |       |     |       |     |        |     |                       |            |                    |
| 1 PLC  | ± -                 |                                  |   |                    |     |       |     |       |     |       |     |        |     |                       |            |                    |
| 2 PLC  | ± -                 |                                  |   |                    |     |       |     |       |     |       |     |        |     |                       |            |                    |
| 3 PLC  | ± -                 |                                  |   |                    |     |       |     |       |     |       |     |        |     |                       |            |                    |
| 4 PLC  | ± -                 |                                  |   |                    |     |       |     |       |     |       |     |        |     |                       |            |                    |
| ANGLES   | ± -                 |                                  |   |                    |     |       |     |       |     |       |     |        |     |                       |            |                    |
| MATERIAL<br>SEE NOTES  | FINISH<br>SEE NOTES | WEIGHT<br>-                      | DRAWING NO<br>C-225382                                    | RESTRICTED TO<br>- |     |       |     |       |     |       |     |        |     |                       |            |                    |
| CUSTOMER DRAWING   |                     |                                  | SCALE<br>10:1   | SHEET<br>1 OF 1    |     |       |     |       |     |       |     |        |     |                       |            |                    |